

# TEC



## BC-4000 TEC

Price Computing Scale with Printer

# BC-400TEC

## Standard Features

- Dual-range weighing
- Static TCP/IP Ethernet communication
- 1 MB internal memory
- Bright VFD display
- 88 assignable preset/function keys
- Fast printing speed
- Multiple label formats for multi-department support
- Flash ROM for remote update of application software
- Proportional tare
- Convenient side-loading label feature

## Specifications

Capacity (dual range):	15lb x 0.005lb/30lb x 0.01lb 6kg x 0.002kg/15kg x 0.005kg
Capacity (single range):	30lb x 0.01lb 15kg x 0.005kg
Display:	Fluorescent (VFD), numeric
Display Items:	Tare: four-digits Unit price: five-digits Weight: five-digits Total Price: six-digits
Preset Keys:	44 one-touch keys 88 preset keys (assign two items per key)
Memory Capacity:	1 MB
Communication:	TCP/IP 10/100 Base T Ethernet
Printing Speed:	3.2" (80mm) per second
Label:	Width: 1.5" - 2.5" (38mm - 64mm) Length: 1.2" - 9.4" (30mm - 240mm)
Label Roll:	Inside diameter: 1.6" (40mm) Outside diameter: 3.9" (100mm)
Label Backing Paper:	Width: Up to 2.6" (66mm)
Weight:	24lbs
Power Supply:	AC100 V / 120 V / 220 V / 240 V, 50/60 Hz
Power Consumption:	Stand-by 50W In operation 100W
Classification:	NTEP certified, COC# 07-005
Warranty:	One-year limited warranty



## Options/Accessories

- Fish platter, 9.5" D x 13.5" W
- Produce platter, 9.5" D x 13.5" W
- Product management software

## Dimensions

Low Profile Model:  
A: 16.1" (410 mm)  
B: 16.3" (414 mm)  
C: 6.7" (171 mm)

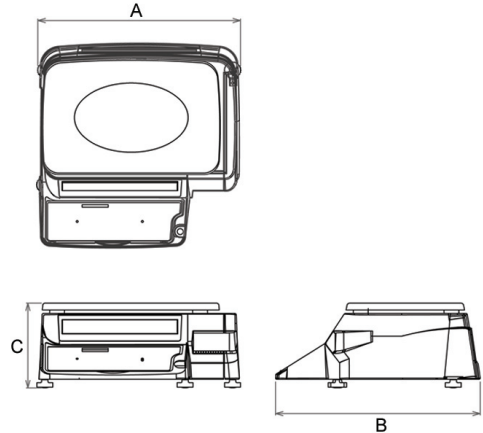

Pole Display Model:  
A: 16.1" (410 mm)  
B: 17.9" (455 mm)  
C: 18.2" (463 mm)

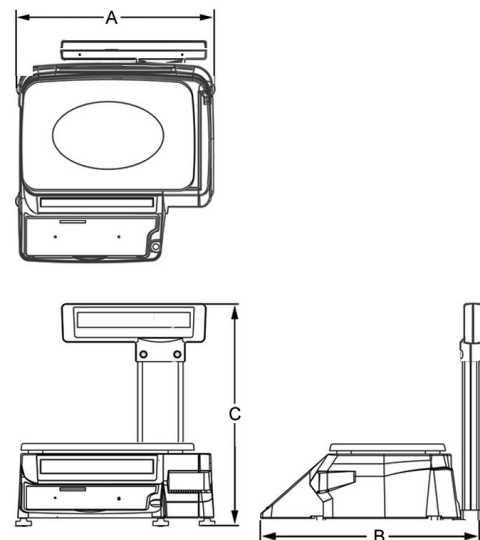

**TOSHIBA**

**TOSHIBA TEC AMERICA**

4401-A Bankers Circle  
Atlanta, GA 30360  
U.S.A.

Phone: 770-449-3040  
Fax: 770-242-9992

Website: [www.toshibatecusa.com](http://www.toshibatecusa.com)